



RHINO-RACK

Rhino-Rack FOXWING ECO Awning 31117

Important: Please read these instructions carefully prior to installation. Please refer to your fitting instruction to ensure that the roof racks are installed in the correct locations. Check the contents of kit before commencing fitment and report any discrepancies. Place these instructions in the vehicle's glove box after installation is complete.

Layout

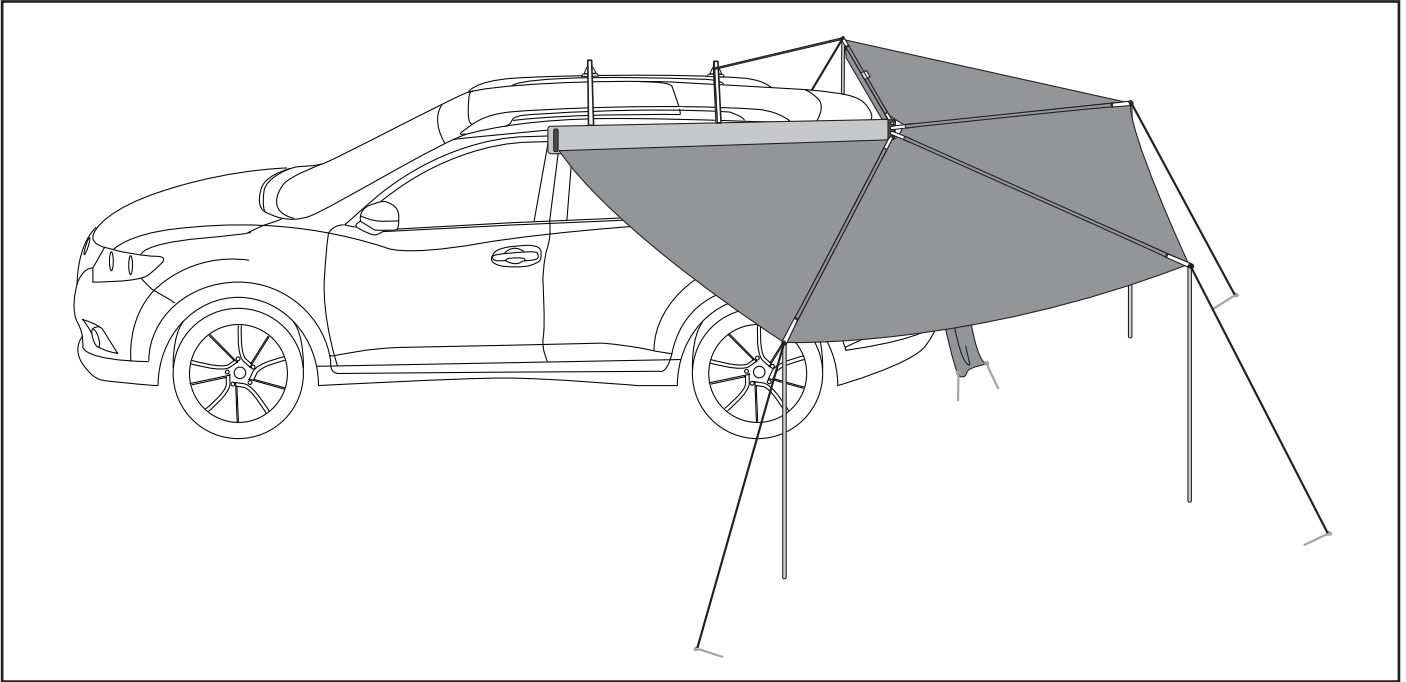

Note: The poles and ropes must always be used when the FOXWING Eco awning is open

Note: The foxwing Eco shade span opens up to 270 degrees (± 5 degrees due to material variation)

Important Information

Recommendations

It is essential that all bolt connections be checked after driving a short distance when you first install your Rhino FOXWING Eco Awning. Bolt connections should be checked again at regular intervals (probably once a week is enough, depending on road conditions, usage, loads and distances travelled). You should also check the roof bars each time they are refitted.

Use only non-stretch fastening ropes or straps.

Please remove FOXWING Eco Awning and crossbars when putting vehicle through an automatic car wash.

Load Ratings

With the addition of the FOXWING ECO Awning, the load capacity of your crossbars will have to be adjusted accordingly. The FOXWING ECO Awning and 2 crossbars weigh approximately 14kg. When roof racks are to be used in off-road conditions, please build a safety factor of 1.5 into this load limit. Although the roof racks are tested and approved to AS1235-2000, Australian road conditions can be much more rigorous.

Note for Dealers and Fitters

It is your responsibility to ensure that this fitting instruction is given to the end user or client.

Rhino-Rack
3 Pike Street, Rydalmere,
NSW 2116, Australia.
(Ph) (02) 9638 4744
(Fax) (02) 9638 4822

Document No: R367
Prepared By: Kayle Everett
Authorised By: Chris Murty

Issue No: 01
Issue Date: 11/03/2014

These instructions remain the property of Rhino-Rack Australia Pty Ltd and may not be used or changed for any other purpose than intended.



Rhino-Rack FOXWING ECO Awning (31117)

General Parts List

Item	Component Name	Qty	Part No.
1	FOXWING Eco Awning (pg 2)	1	-
2	Crossbar Bracket	2	C774
3	Crossbar Bracket Plate	2	C785
4	M8 x 23mm T-Bolt	4	C779
5	M8 X 17mm Flat Washer	6	W020
6	M8 Nyloc Nut	6	N028
7	Sportz / Aero Crossbar Insert	2	CA1197
8	M8 X 25mm T-Bolt	2	B084
9	M8 Spring Washer	2	W019
10	M8 x 30mm Hex Bolt	2	B026
11	Heavy Duty Crossbar Insert	2	CA1198
12	M8 Channel Nut	2	N003
13	Telescopic Support Pole	4	31106
14	Metal Peg	10	C909
15	Guy Rope	8	C910
16	Tensioning Straps	1	C820
17	Fitting Instruction	1	RR227

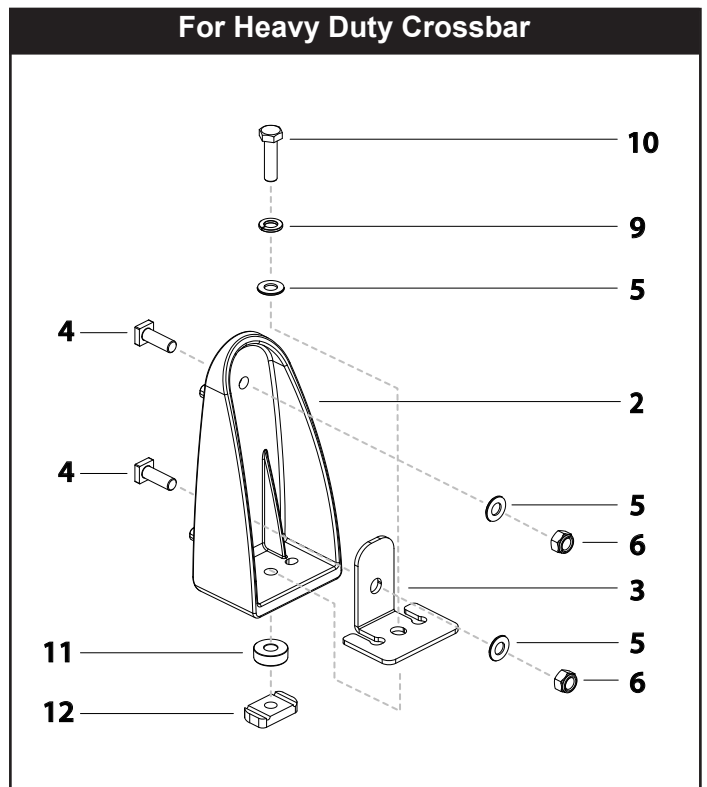
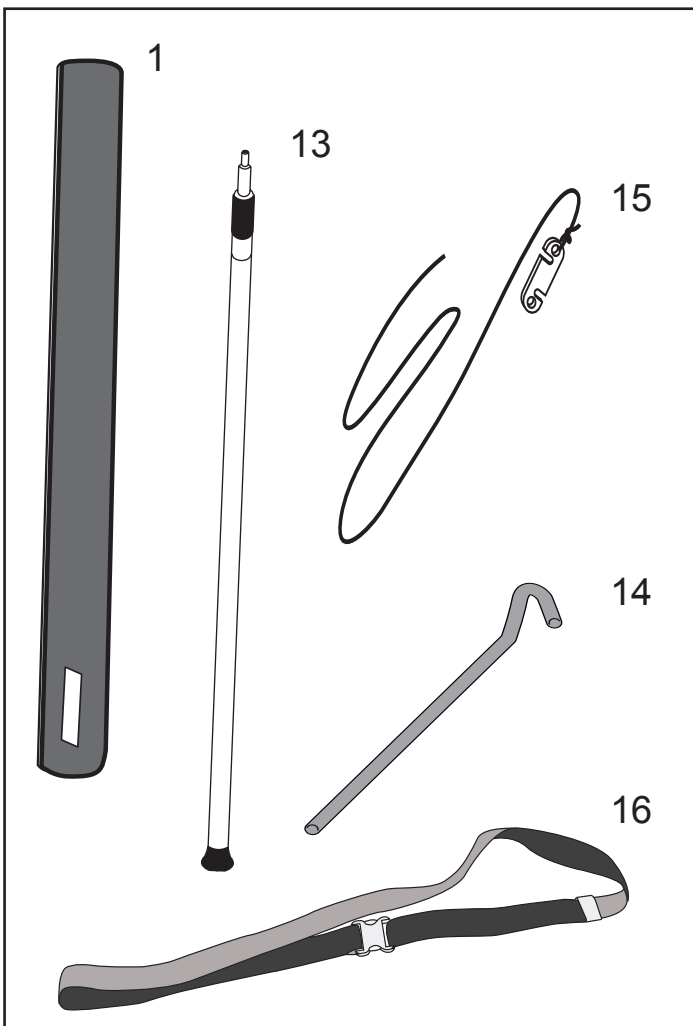
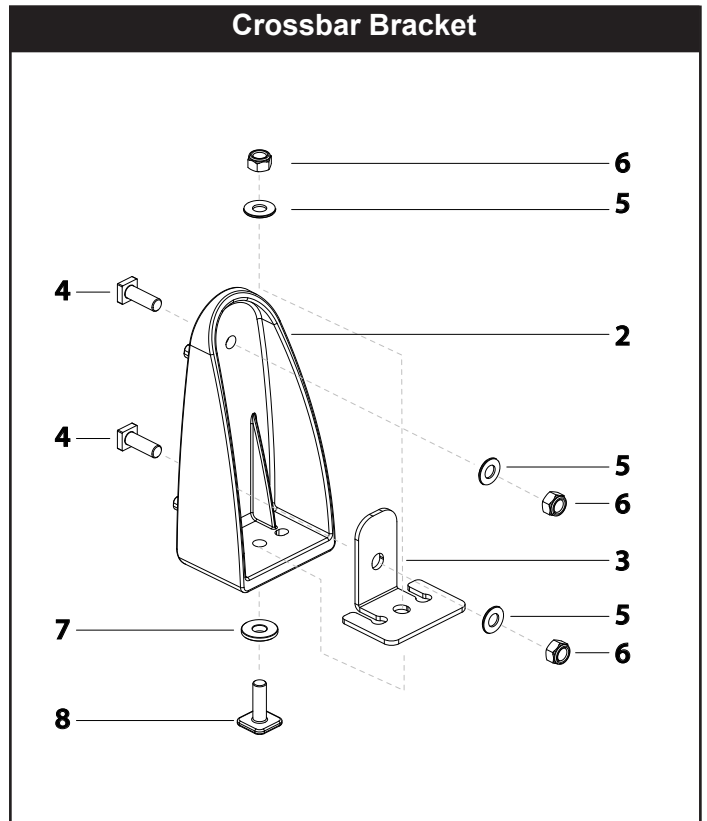

Tools Required:

Tape measure, 13mm spanner, 14mm spanner, Knife

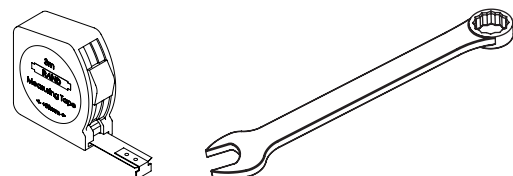

Care Instruction:

Wash and clean vehicle roof racks prior to fitment



Rhino-Rack FOXWING ECO Awning (31117)

Foxwing Parts List

Item	Component Name	Qty	Part No.
1	End Cap	1	C778
2	Rubber Strap	1	C783
3	Rivet (1661 - 0613)	4	H004
4	Pole Holder	1	C782
5	Rivet (1661 - 0619)	4	H008
6	Backing Extrusion	1	-
7	M8 x 150mm Bolt	1	C775
8	M8 Flat Washer	2	W020
9	Hinge Pin	2	C770
10	Spar Hinge	1	C777
11	M8 Nyloc Nut	1	N028
12	Spar Hinge Insert	4	CA1186
13	Spar Hinge Insert (spares)	2	CA1186
14	Awning Pole	4	-
15	Pole End Cap	4	C784
16	Pole End Cap Rivet and Washer (Black)	8	C789
17	Self tapping screw	8	CA1199
18	Awning Bag	1	-
19	Tensioning Strap	1	C820

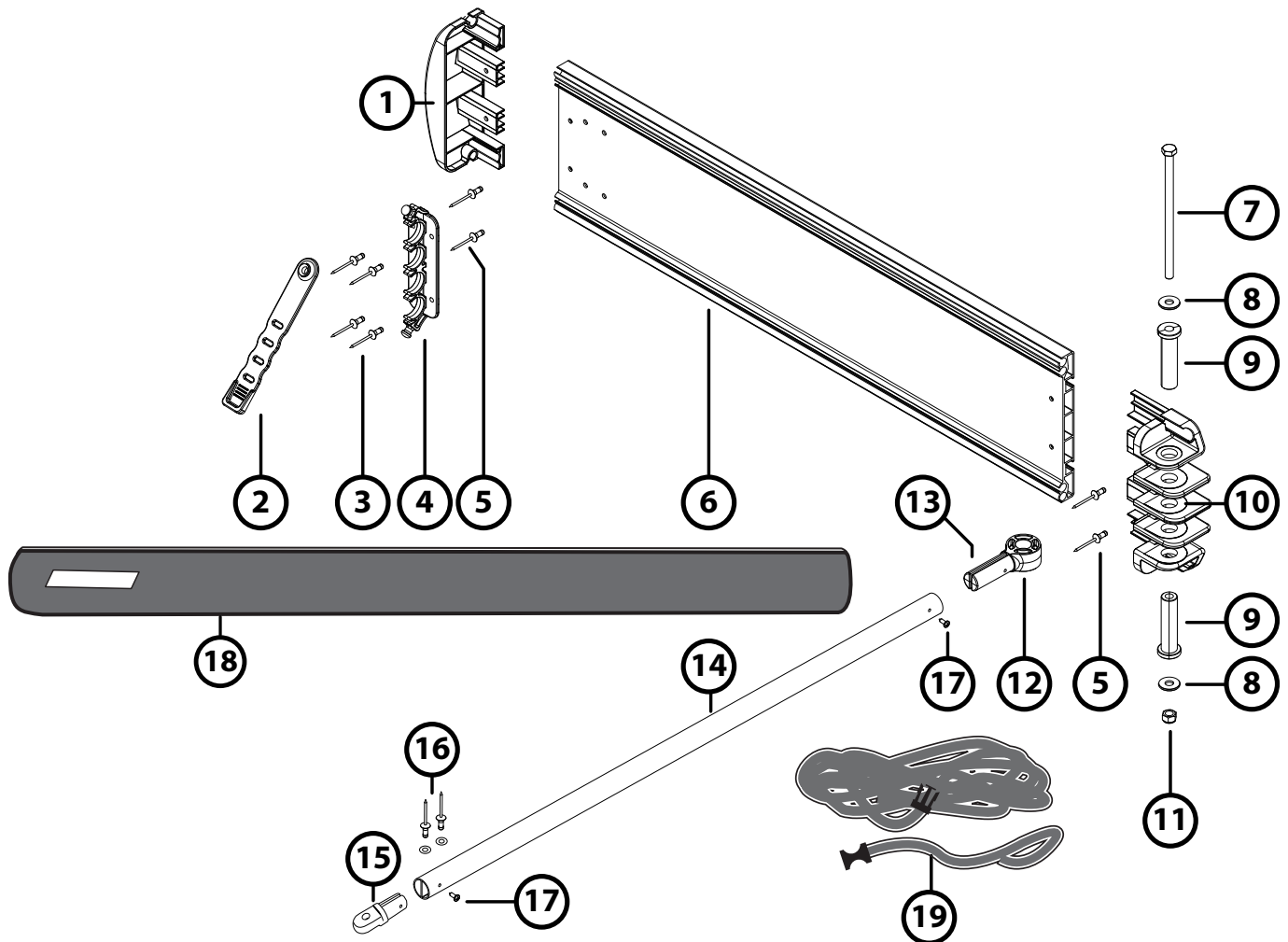



Rhino-Rack FOXWING ECO Awning (31117)

Minimum Crossbar Distance

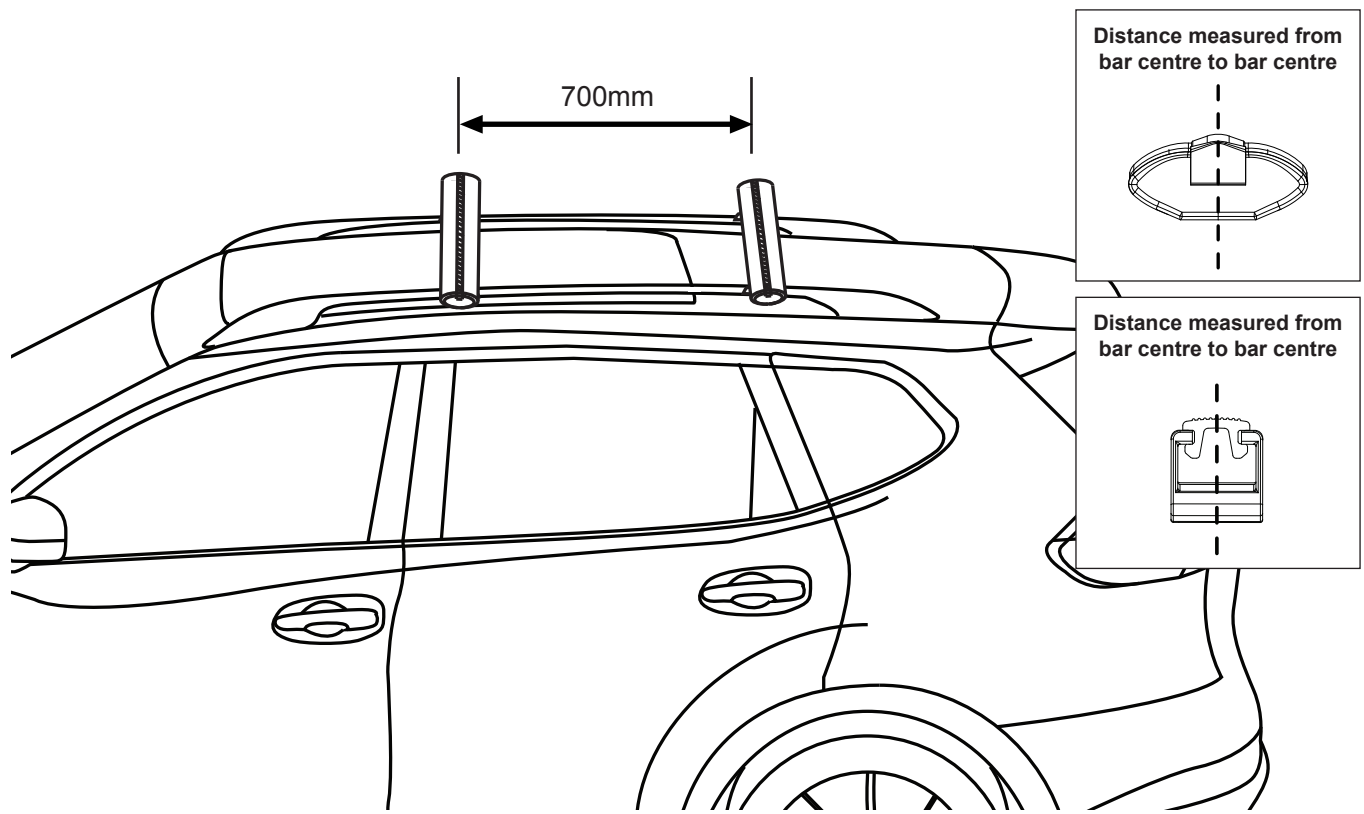

Fitting Instruction

- 1 When locating and inserting each T-bolt (A), ensure that you do not drop it into the recess.

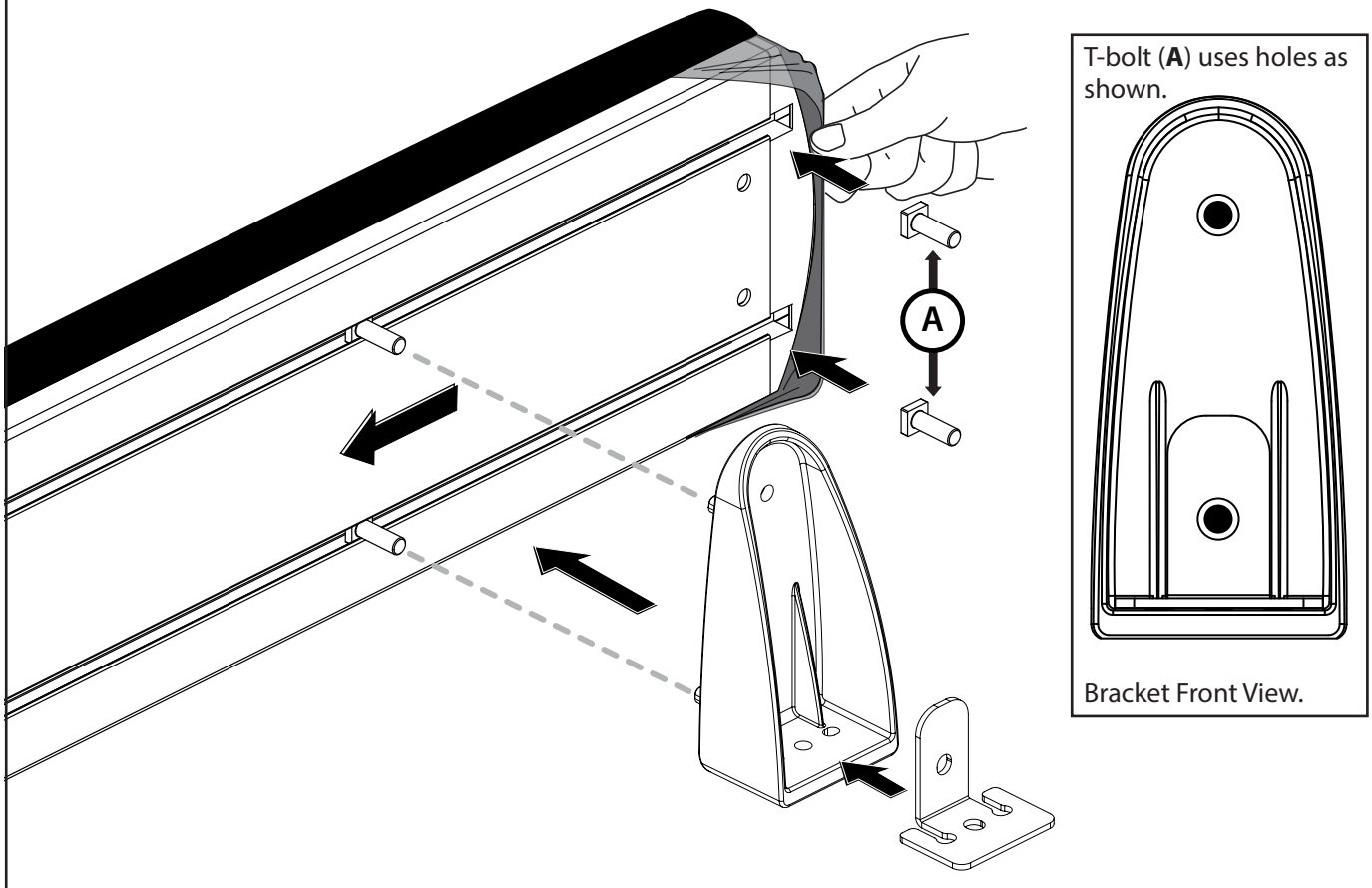



Rhino-Rack FOXWING ECO Awning (31117)

2A For Sportz / Aero Crossbar

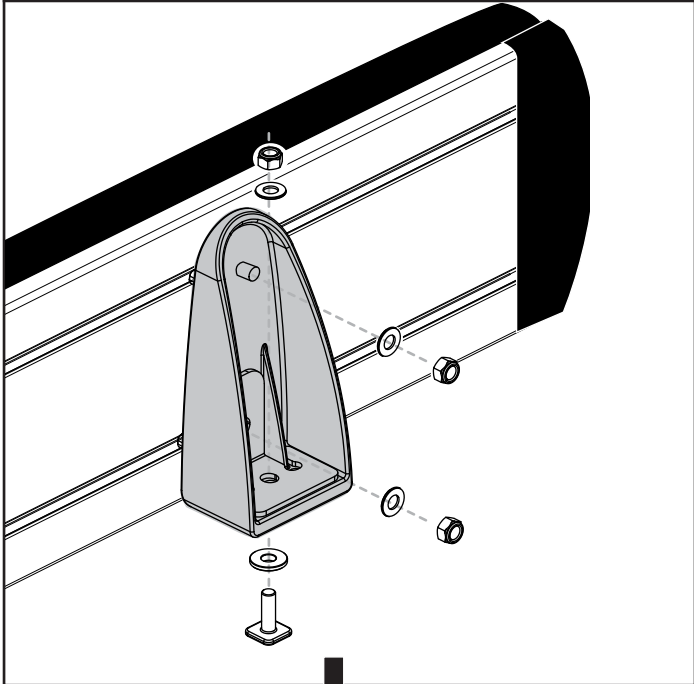

2B For Heavy Duty Crossbar

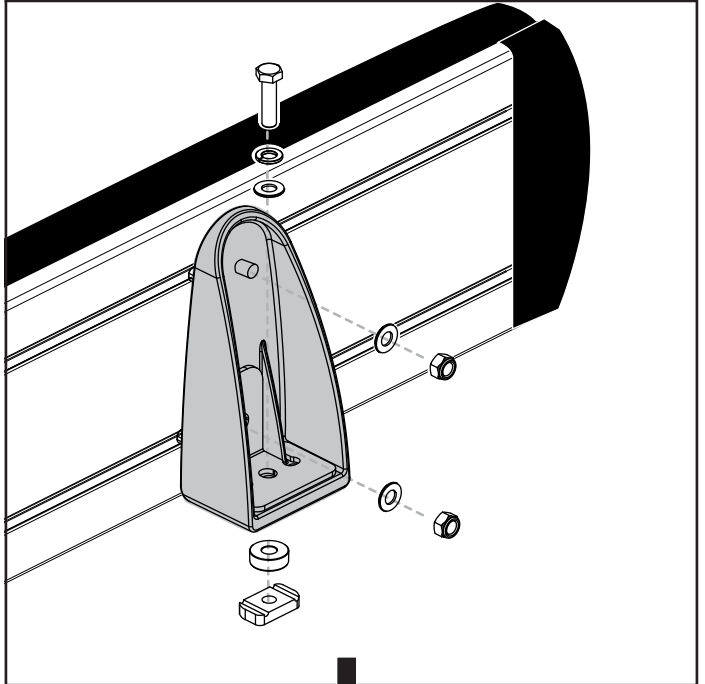

3A

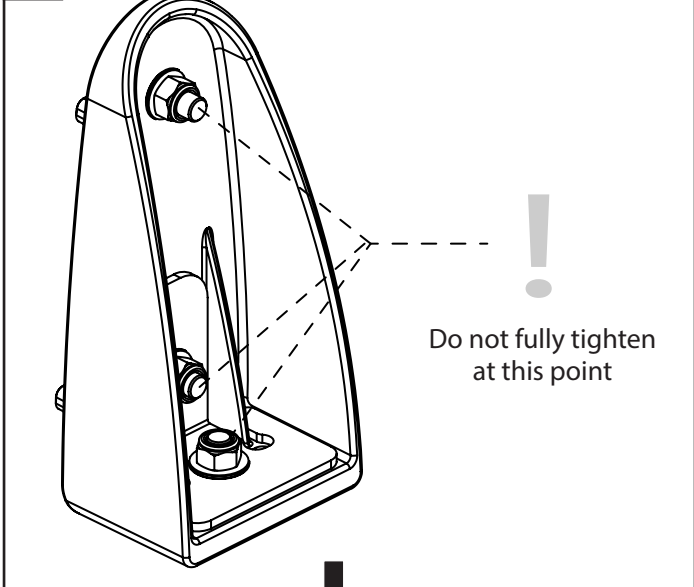

3B

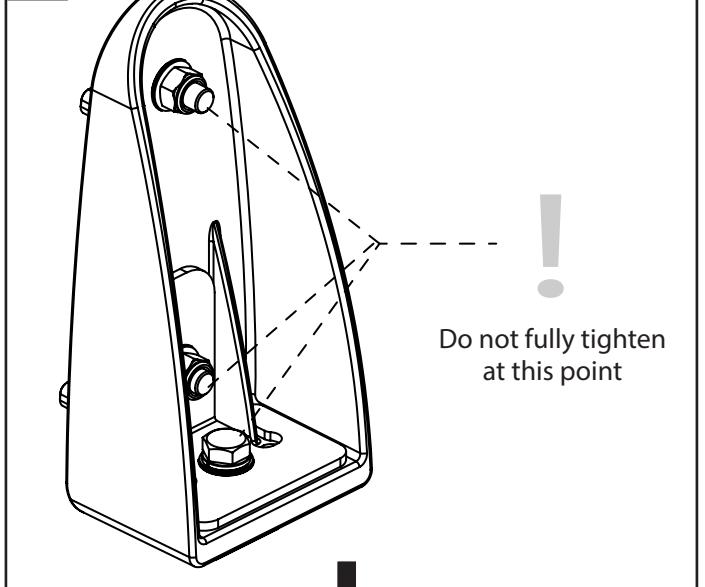

4A

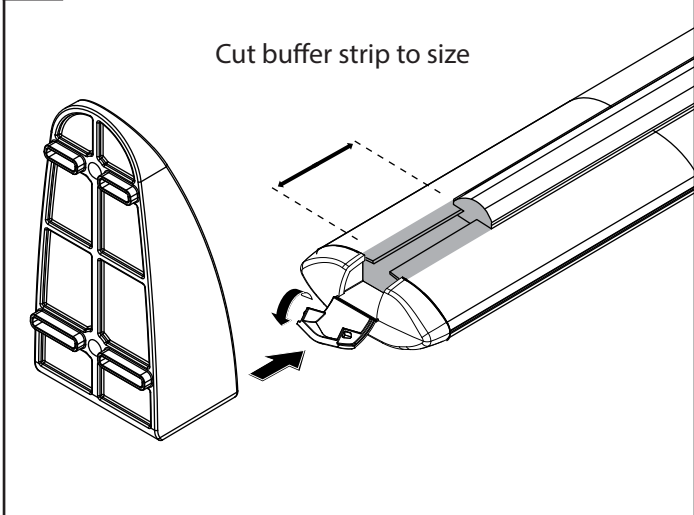

4B

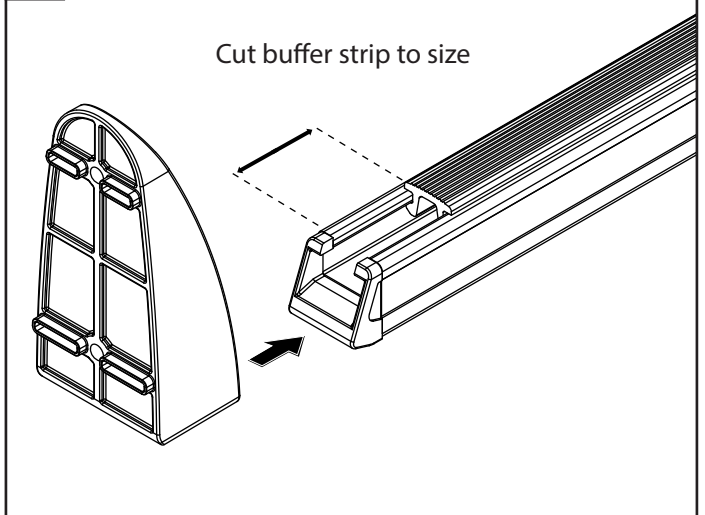



Rhino-Rack FOXWING ECO Awning (31117)

5A Adjust the location of the crossbar bracket assembly to suit the crossbar distance on your vehicle

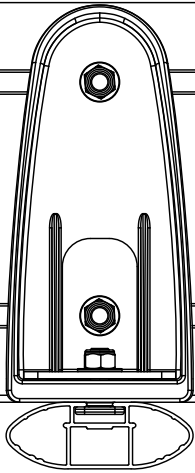

Side View

5B Adjust the location of the crossbar bracket assembly to suit the crossbar distance on your vehicle

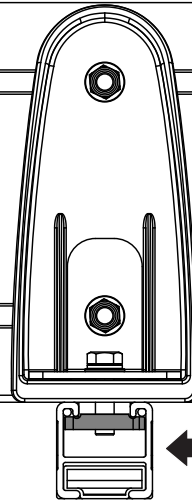

Side View

Channel nut must sit across the bar when tightened

6 Adjust the position of the FOXWING awning, paying extra attention to the rear overhang. Make sure that there is enough room to swing the awning open and it is free from obstruction (i.e. rear tail gate).

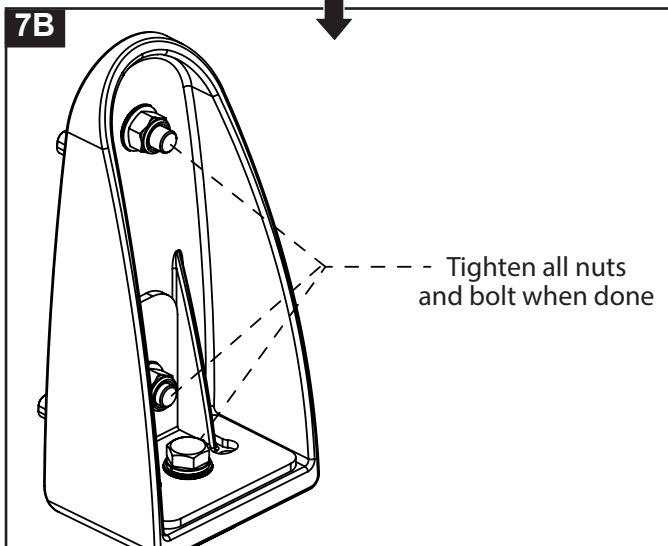
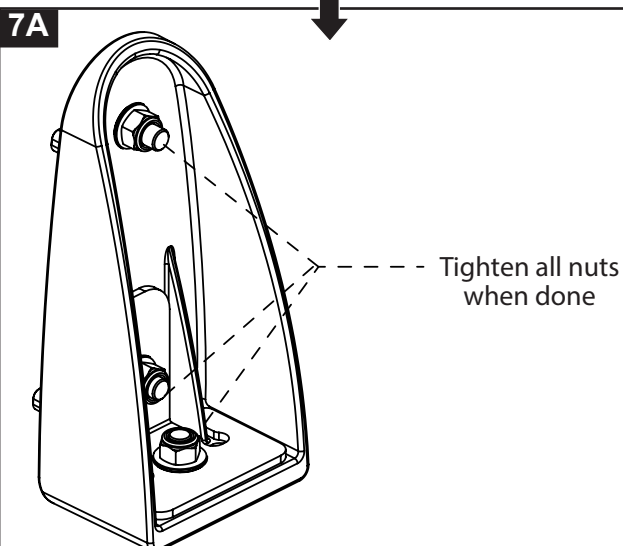
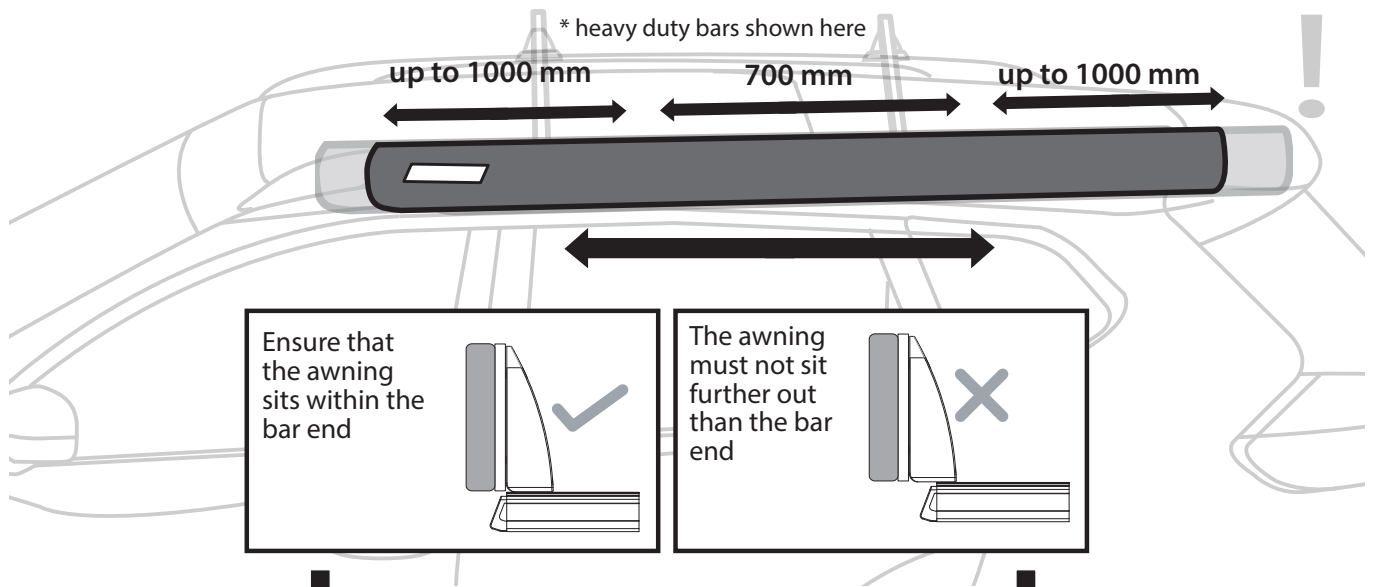



Rhino-Rack FOXWING ECO Awning (31117)

Operation Instruction

1

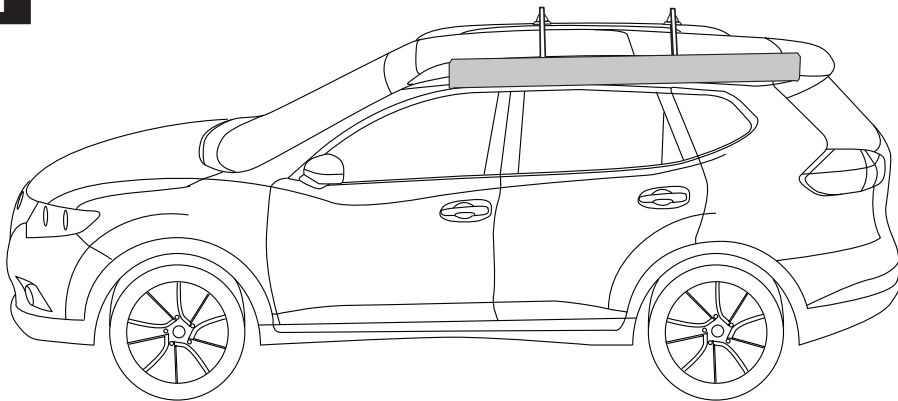

Note: Be careful in windy conditions, assistance from a second person is recommended. Refer to supplement.

2

Front of Car

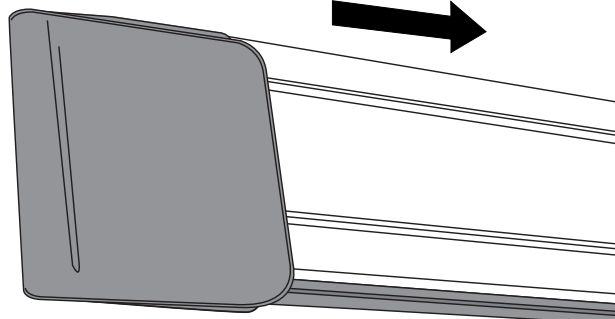

Open awning bag, see steps 3 - 5 for instructions on how to undo the velcro flaps.

3

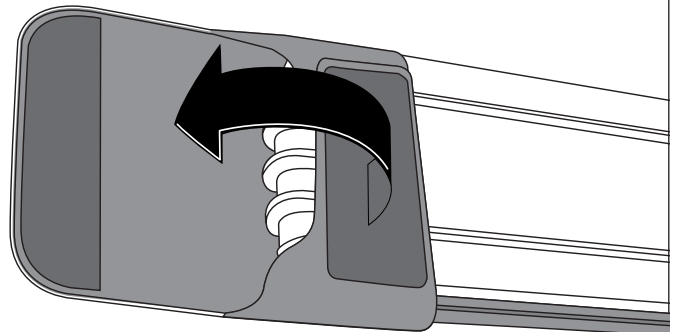

4

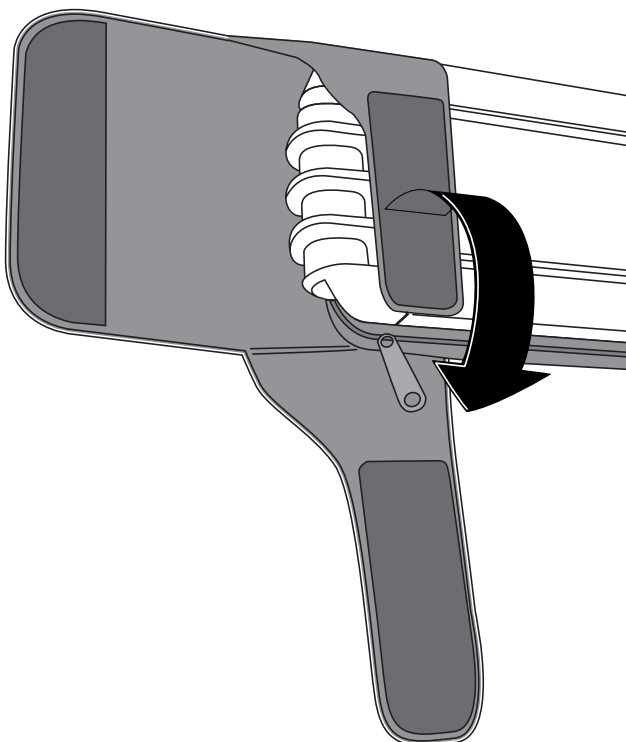

5

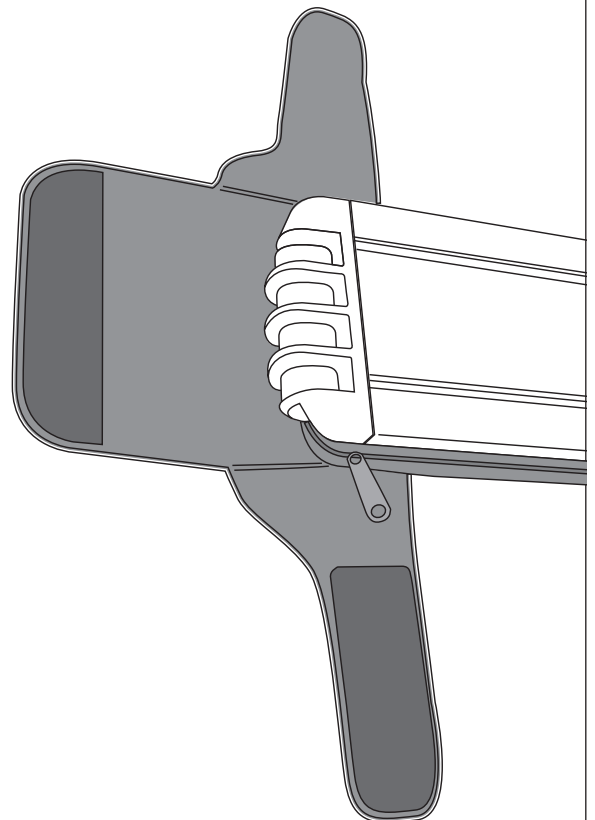



Rhino-Rack FOXWING ECO Awning (31117)

6

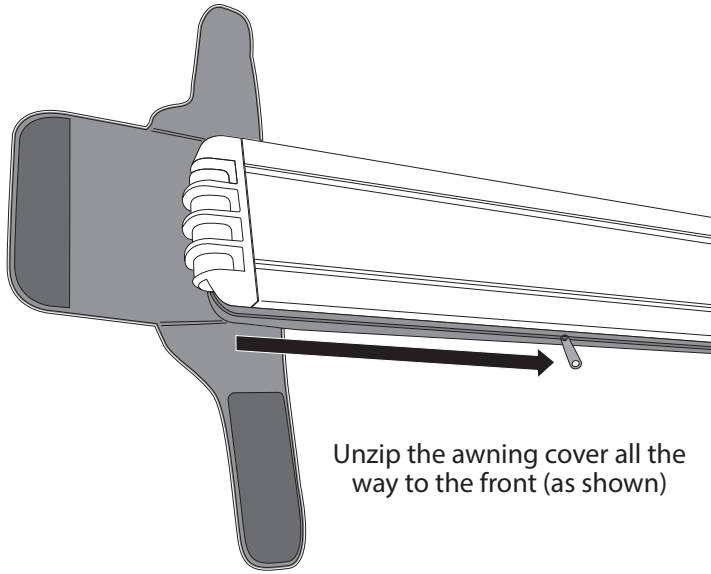

Unzip the awning cover all the way to the front (as shown)

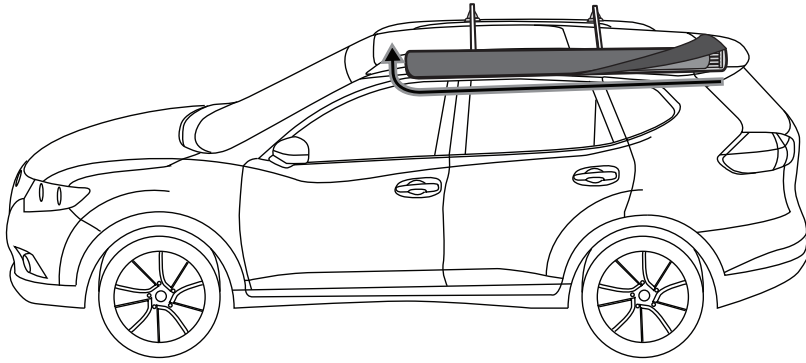

7

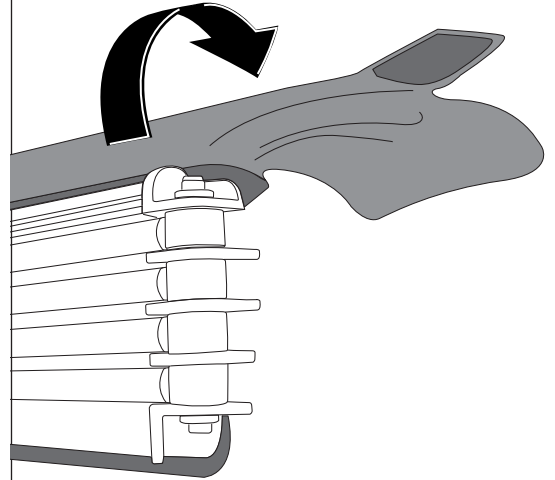

Peel the cover to the rear as shown. Make sure when opening the awning that the bag is clear of the hinge area

8

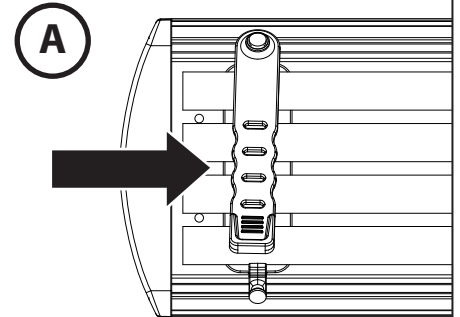
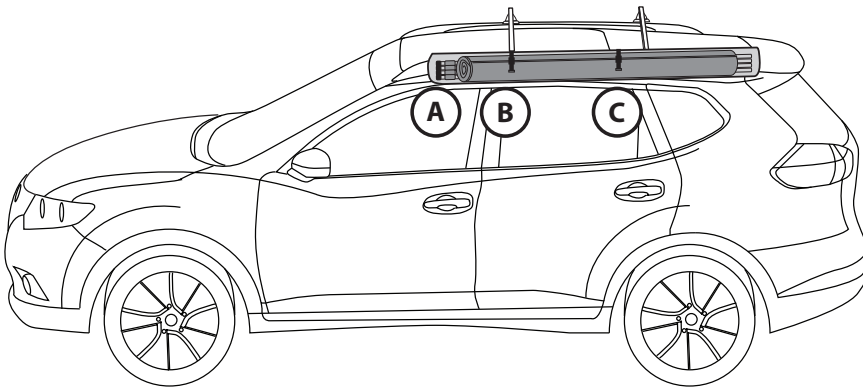

Undo the rubber latch at (A) and the 2 clips at (B) and (C)

9

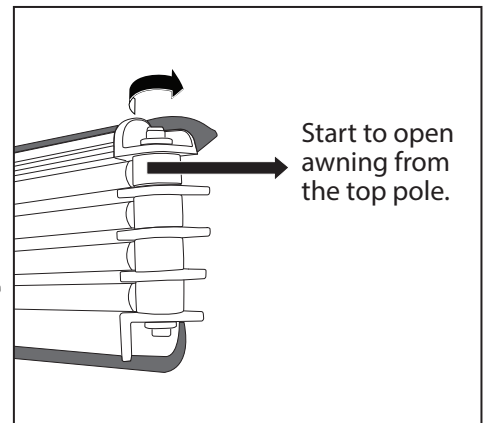
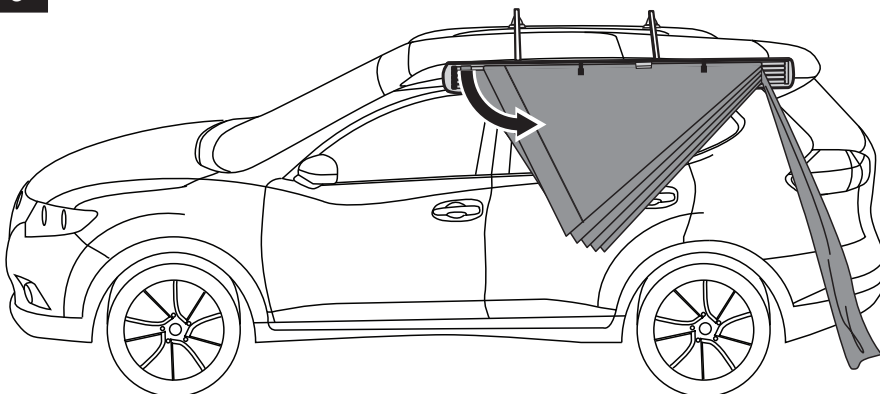



Rhino-Rack FOXWING ECO Awning (31117)

10

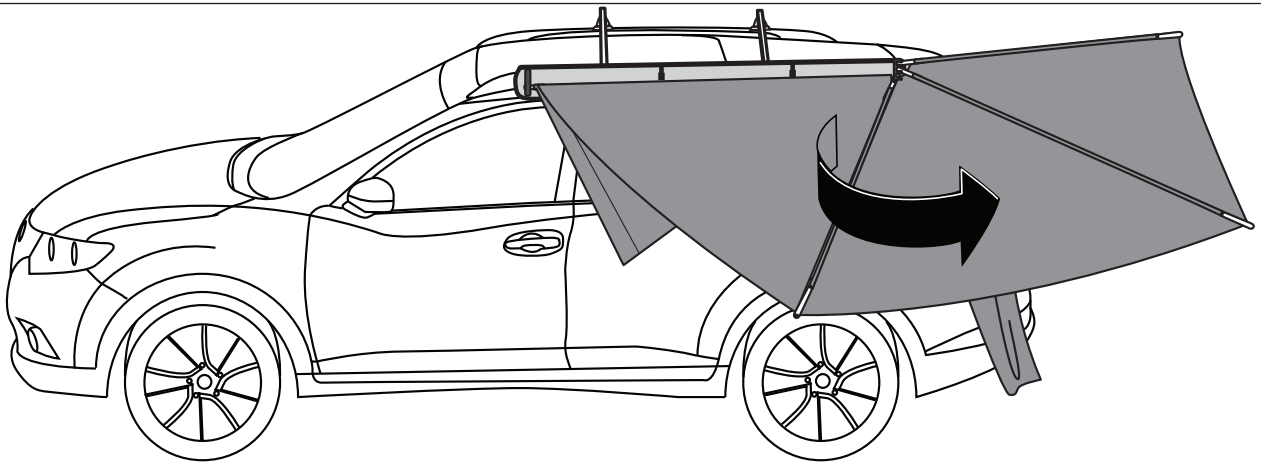

11

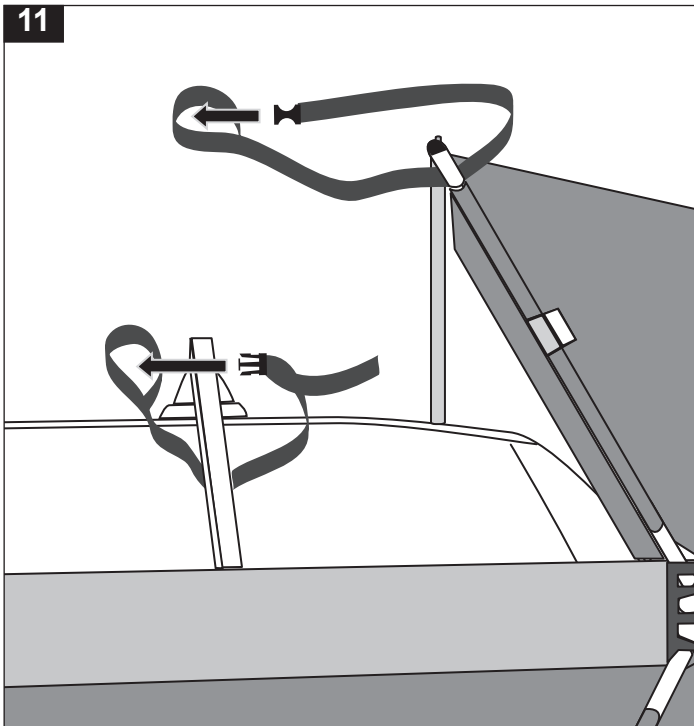

12

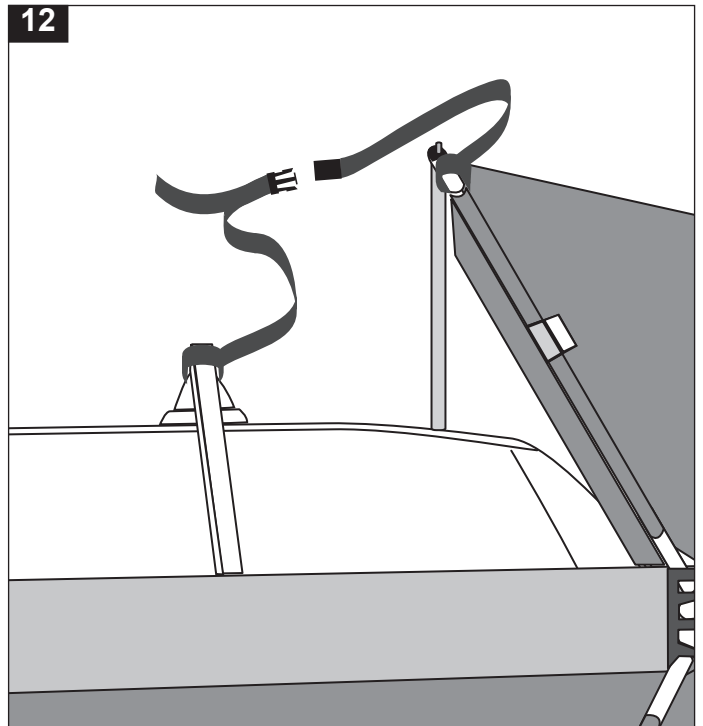

13

Secure the top pole onto the nearest crossbar. Pull the strap tightly (as shown) to maintain tension and shape of the awning.

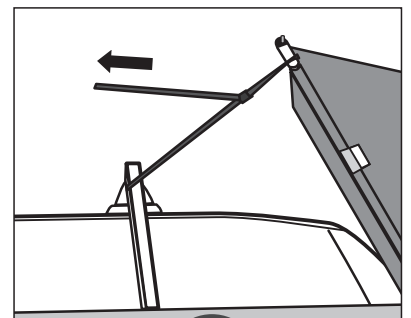
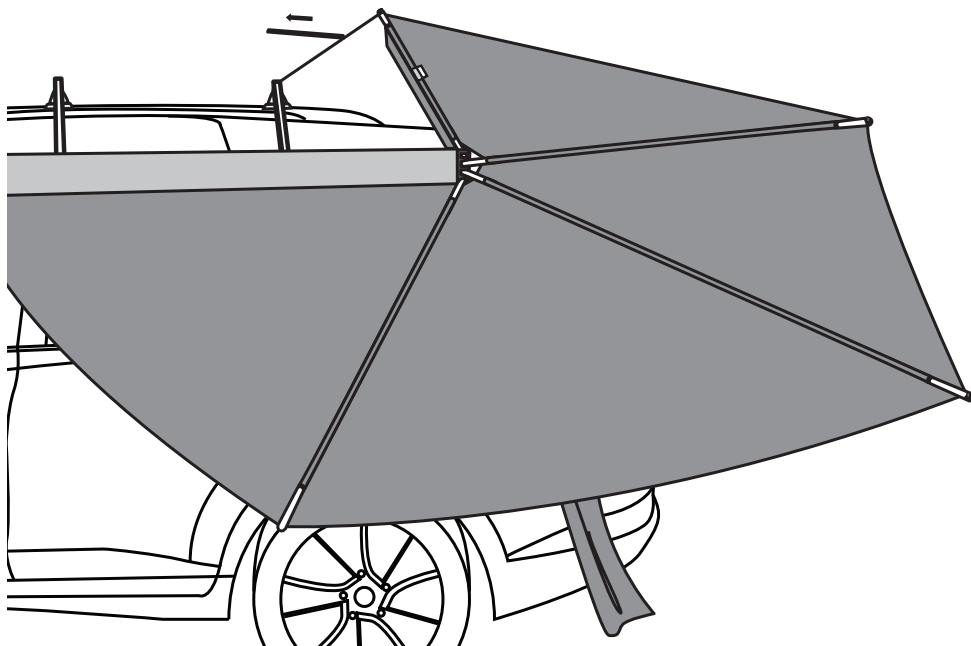

OR

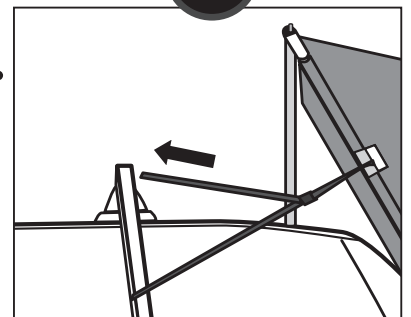



Rhino-Rack FOXWING ECO Awning (31117)

14

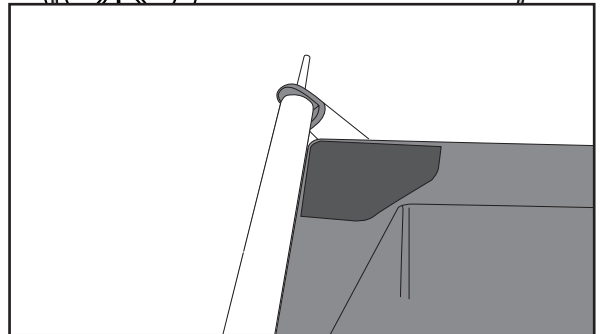
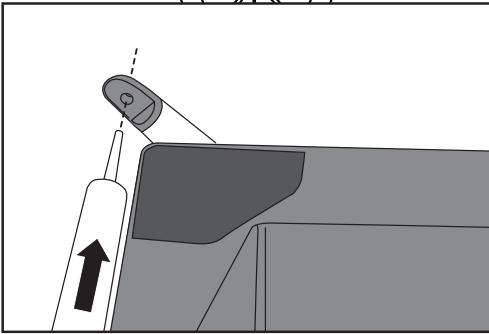
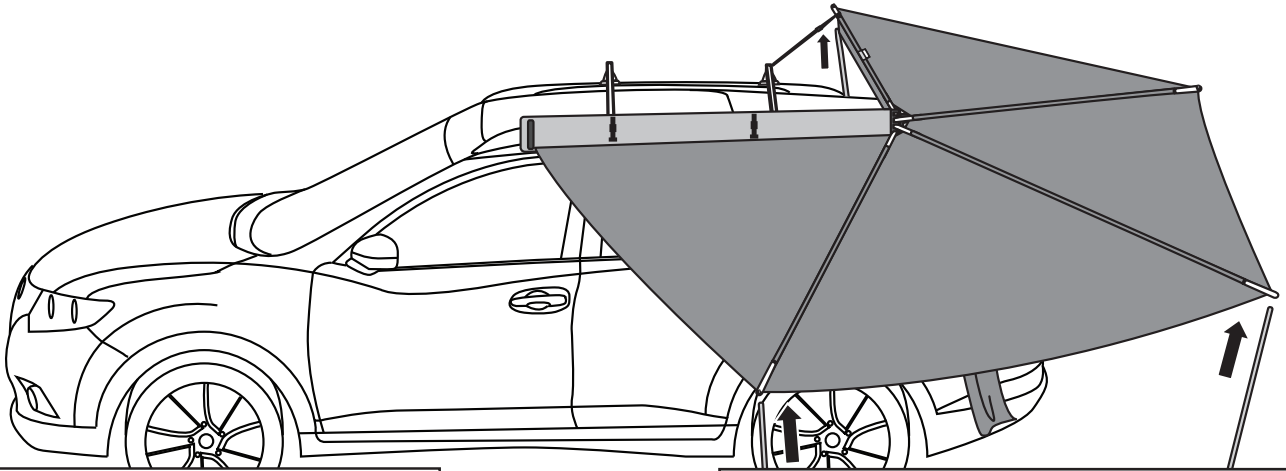

15

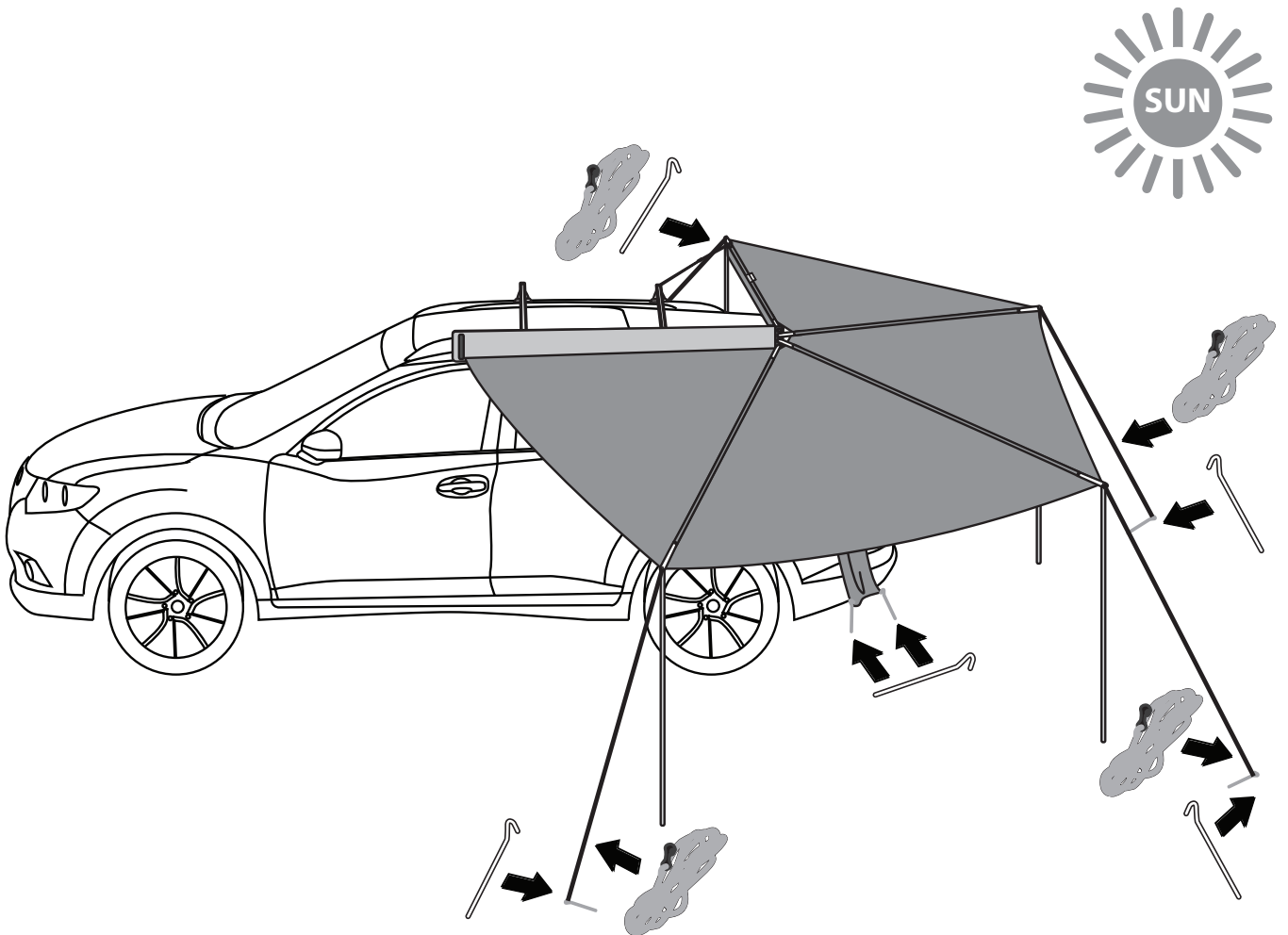



Rhino-Rack FOXWING ECO Awning (31117)

16

Shorten the telescopic pole slightly

Secure the awning with the extra pegs and guy ropes as shown.

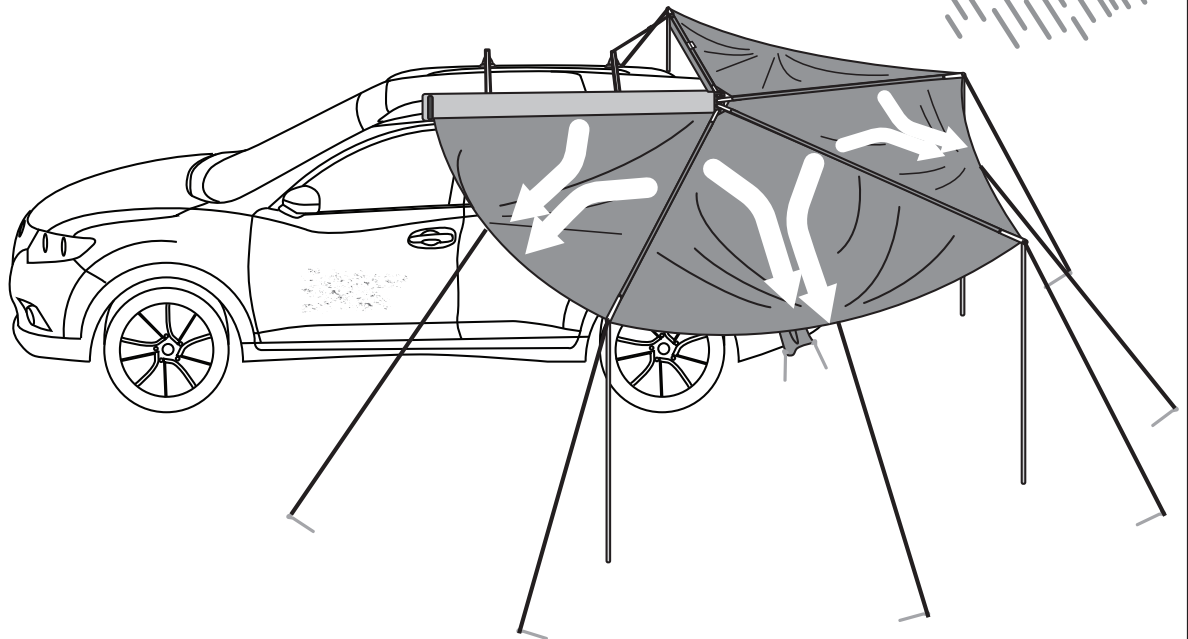
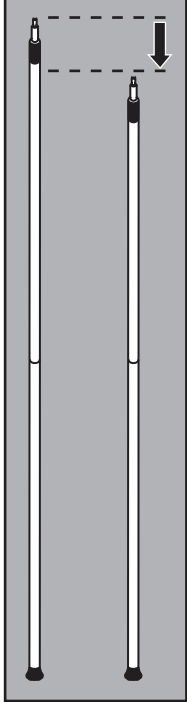

Storing Instruction

17

Undo the tensioning straps, the telescopic poles, guy ropes and pegs. Store these items in the supplied travel bags.

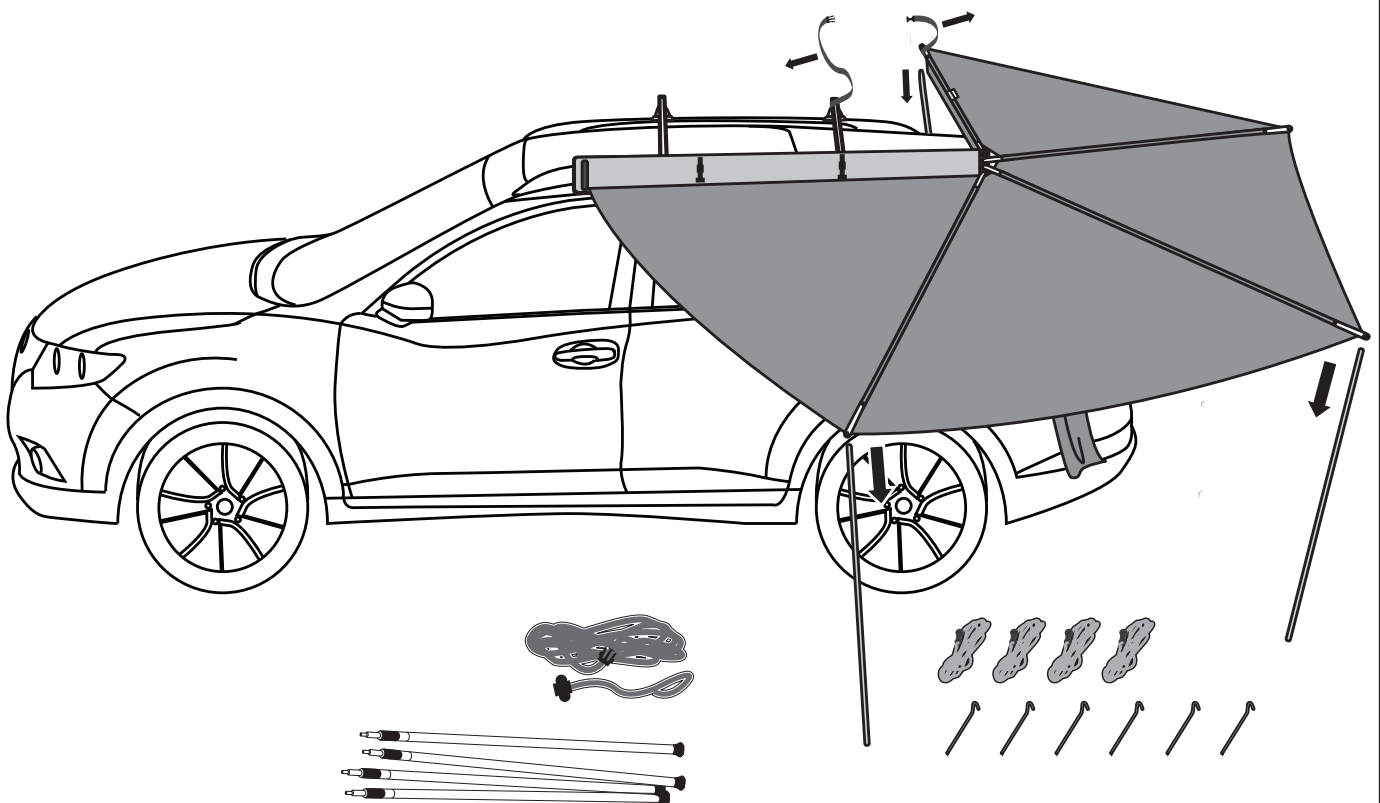



Rhino-Rack FOXWING ECO Awning (31117)

- 18** Secure the poles with the rubber strap before rolling awning material up (see inset picture).

Fold the awning as shown on right.

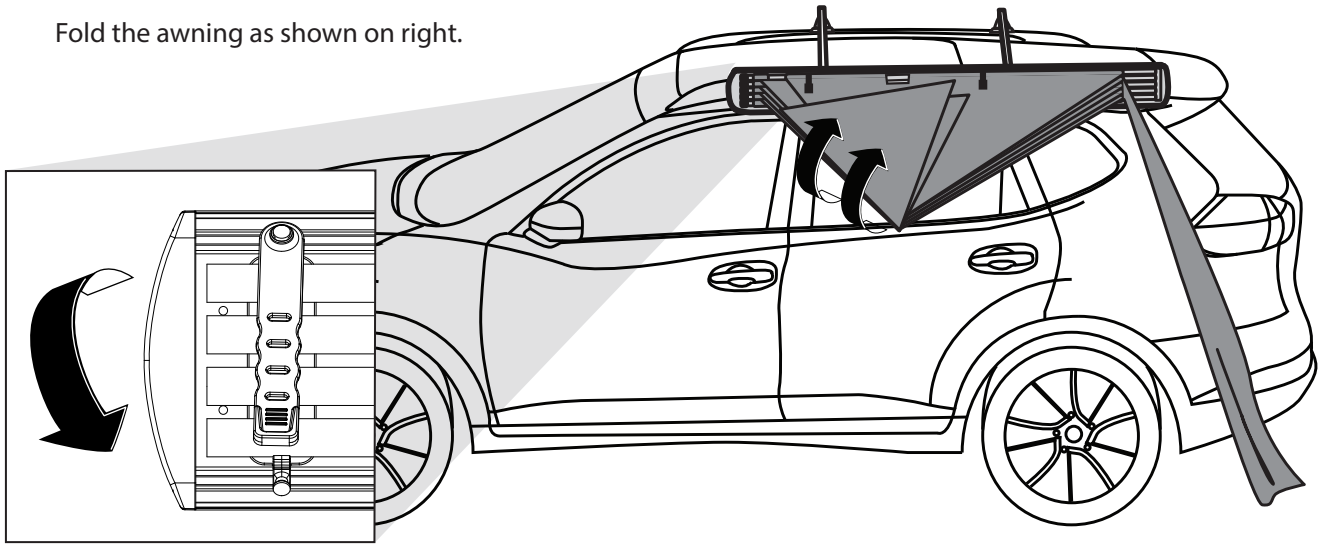

- 19** Roll the awning all the way up till you see the corresponding clips (A). Position the drain pipe (B) as shown. Clip awning into place.

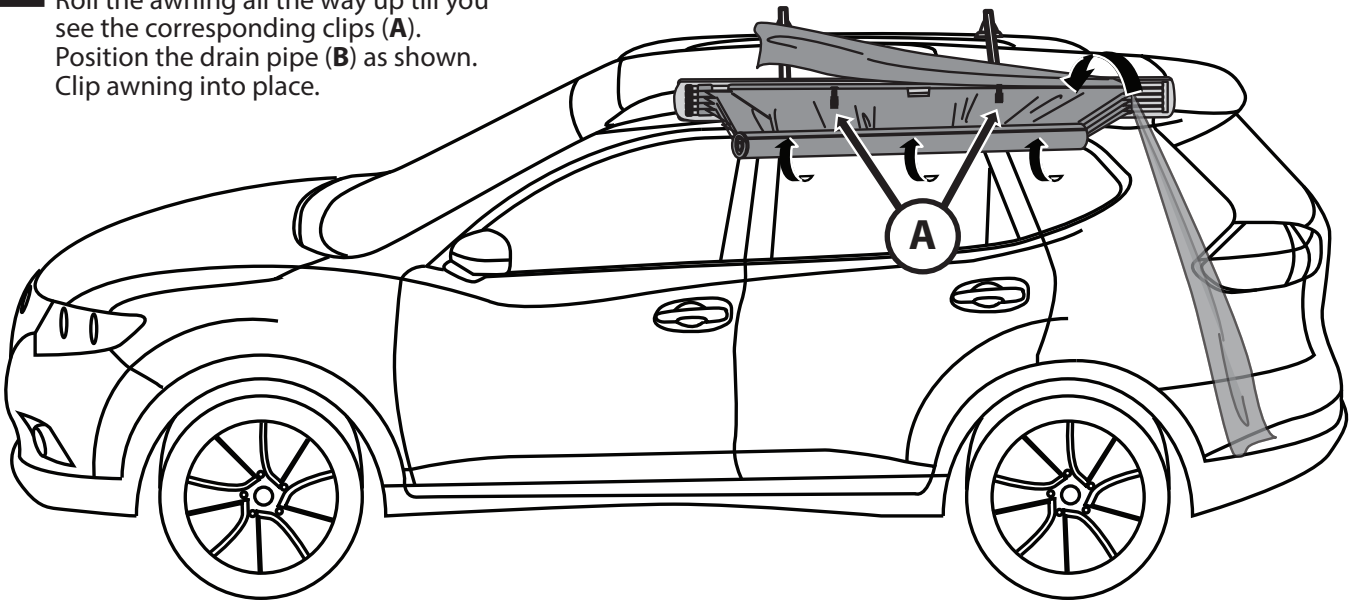

20

Tuck the excess awning by pushing it upwards as you pull the zip along the cover. This will prevent the awning from being caught up and damaged between the zipper.

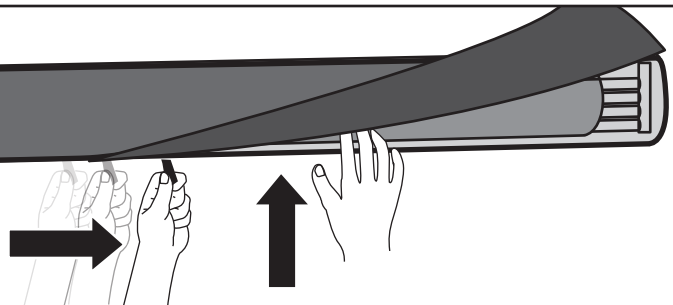

Secure the flaps so that the bag is fully enclosed (Refer steps 2 - 6).

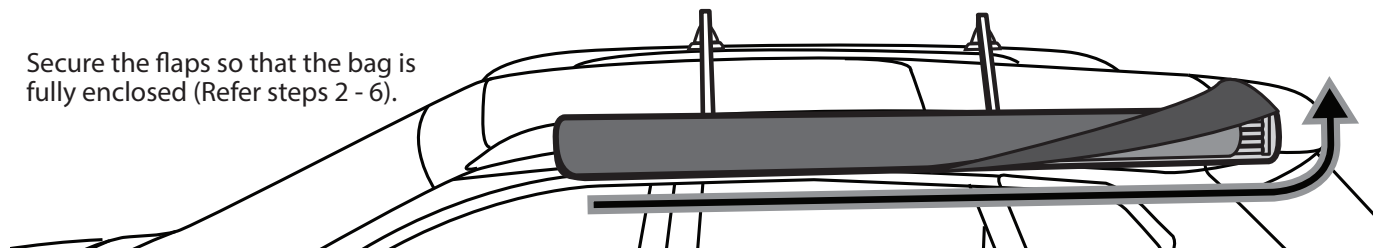



Rhino-Rack FOXWING ECO Awning (31117)

Replacing the spar hinge

- 1 Should the spar hinge be damaged from stronger than expected windy conditions, please follow these steps to replace the spar hinge (we have included 2 spares with this kit). Open the awning bag and expose the spar hinge assembly as shown.

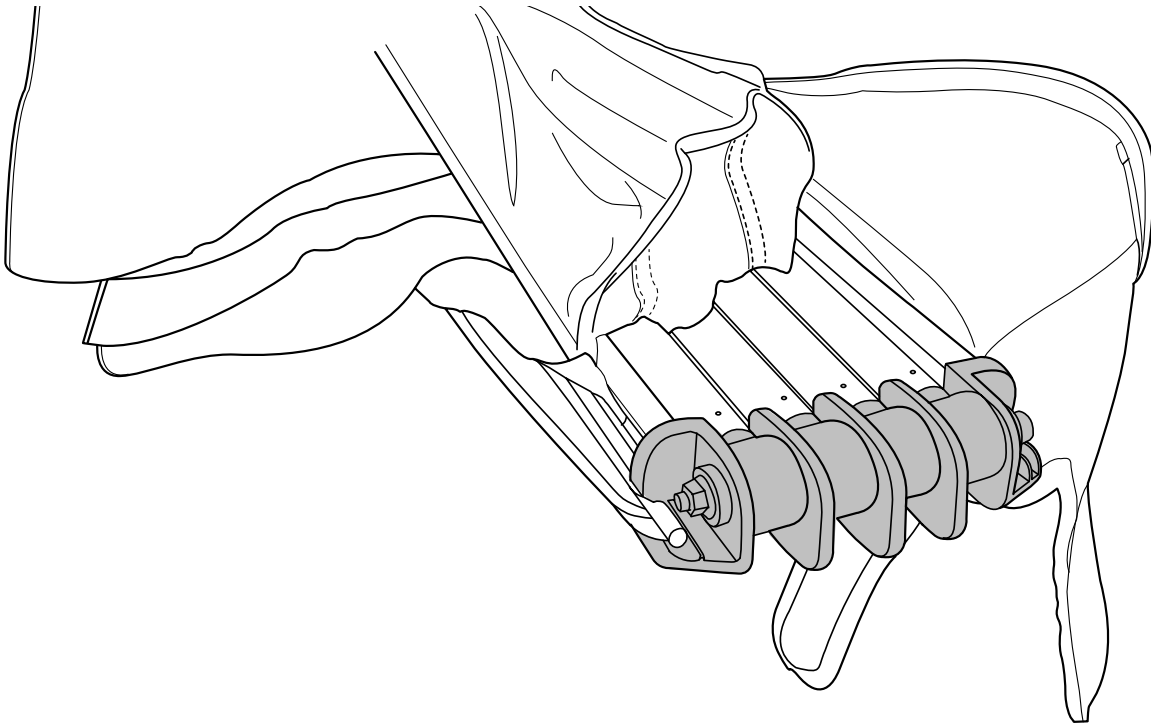

- 2 Use a 17mm spanner and a 6mm allen key to undo the skewer on the spar hinge assembly.

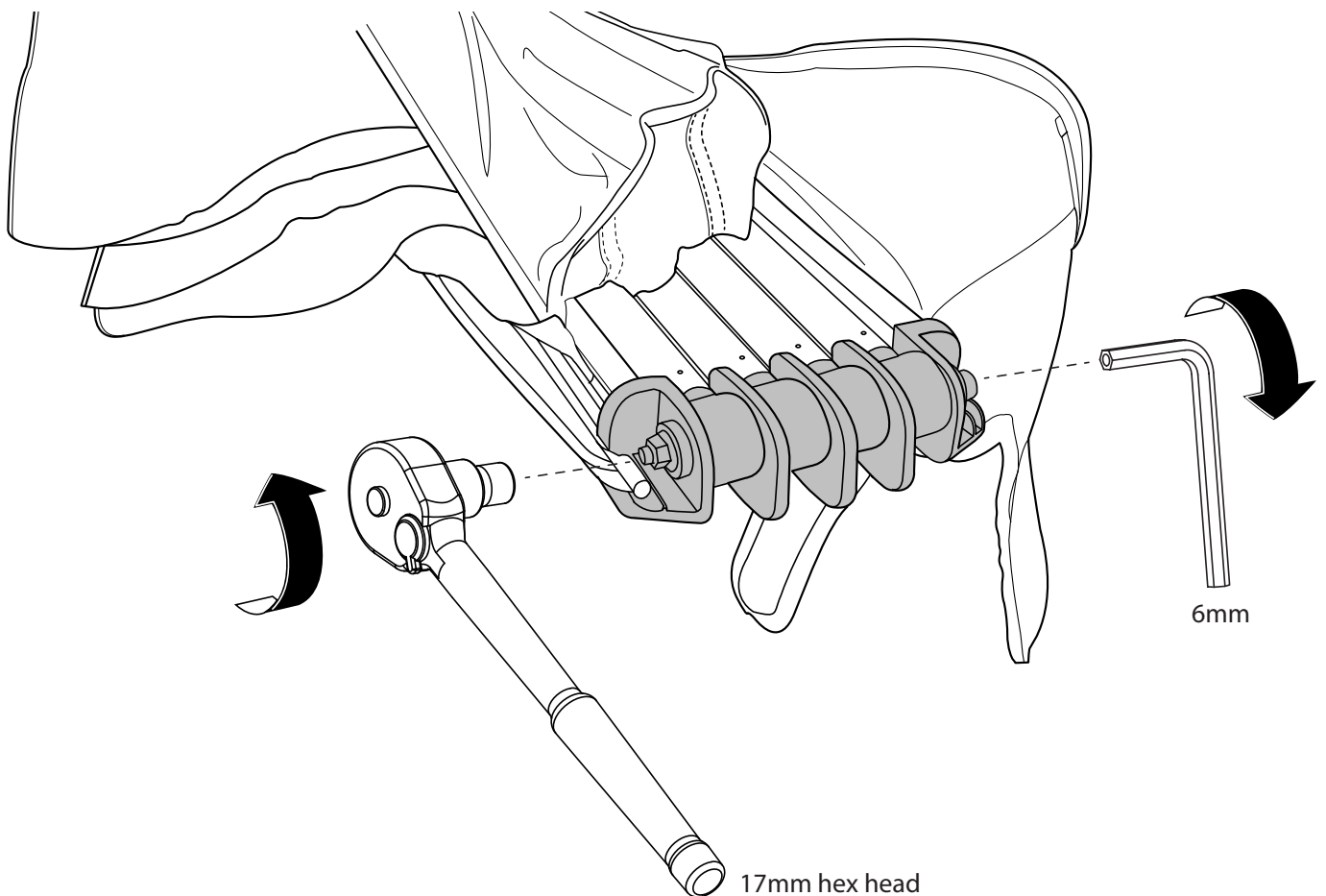



Rhino-Rack FOXWING ECO Awning (31117)

- 3** Disassemble the skewer as shown.

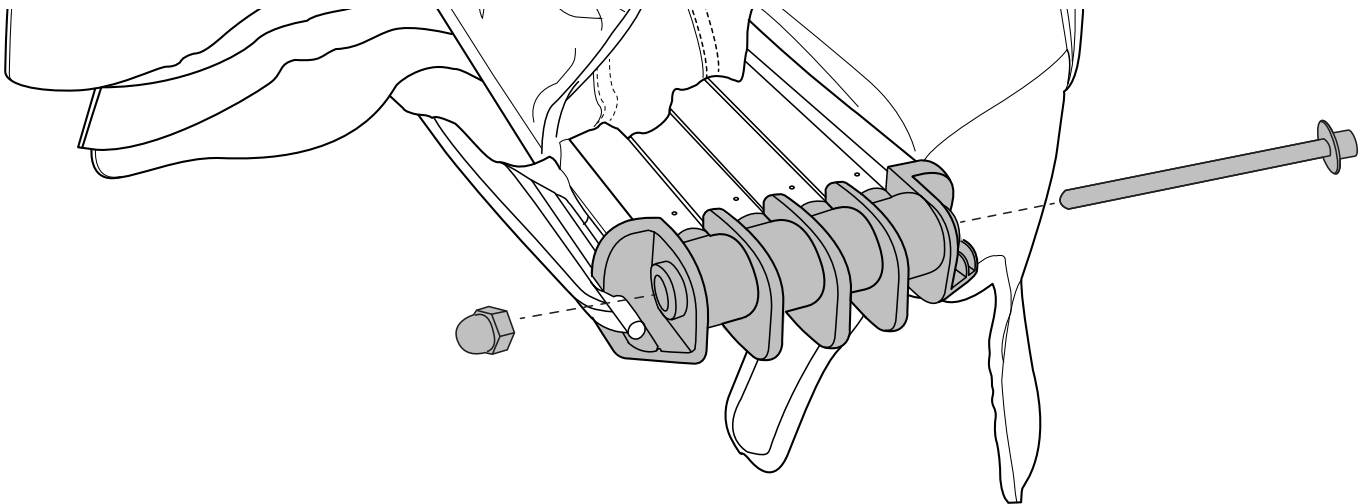

- 4** Determine which spar hinge that needs to be replaced. Pull out the corresponding hinge pin.

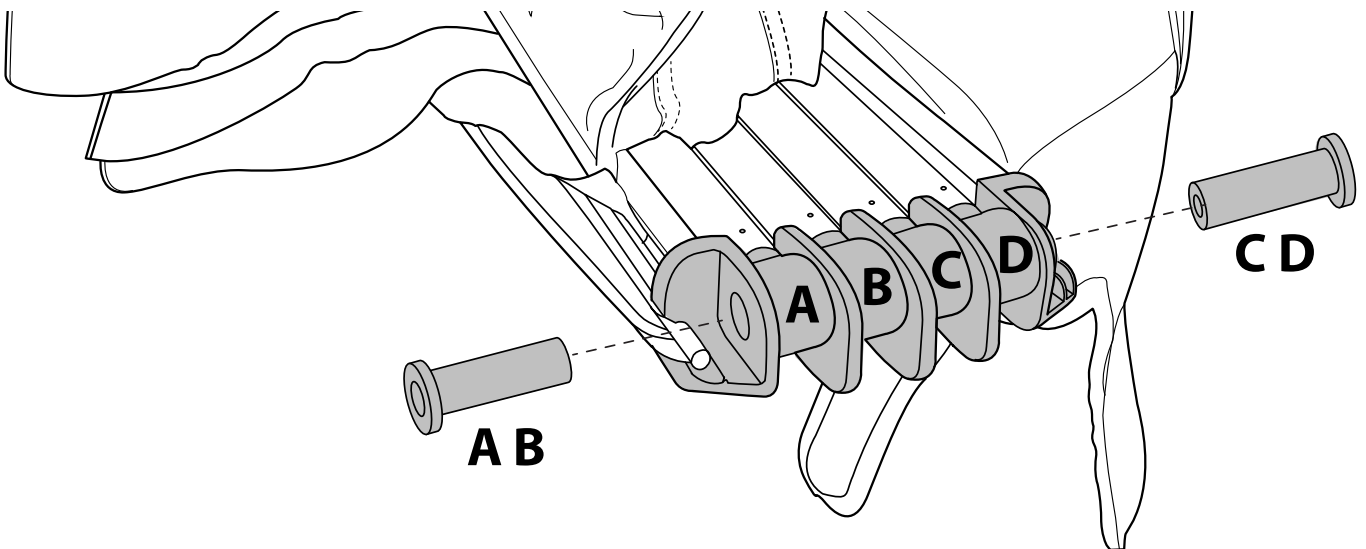

- 5** Undo the self tapping screw to release the spar hinge

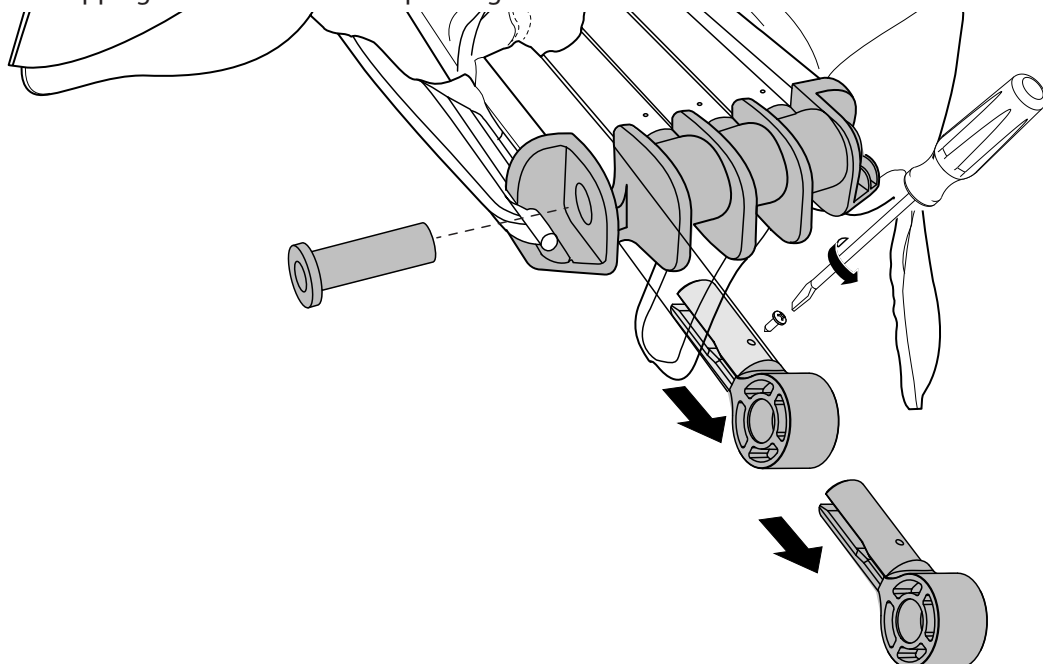



Rhino-Rack FOXWING ECO Awning (31117)

- 6** Insert replacement spar hinge and self tapping screw as shown.

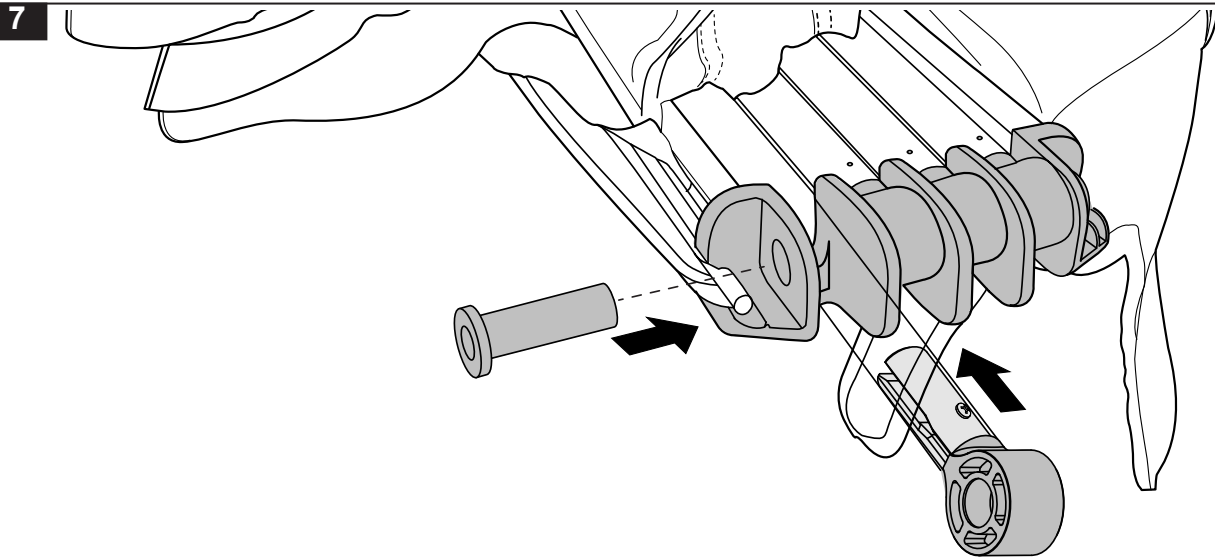
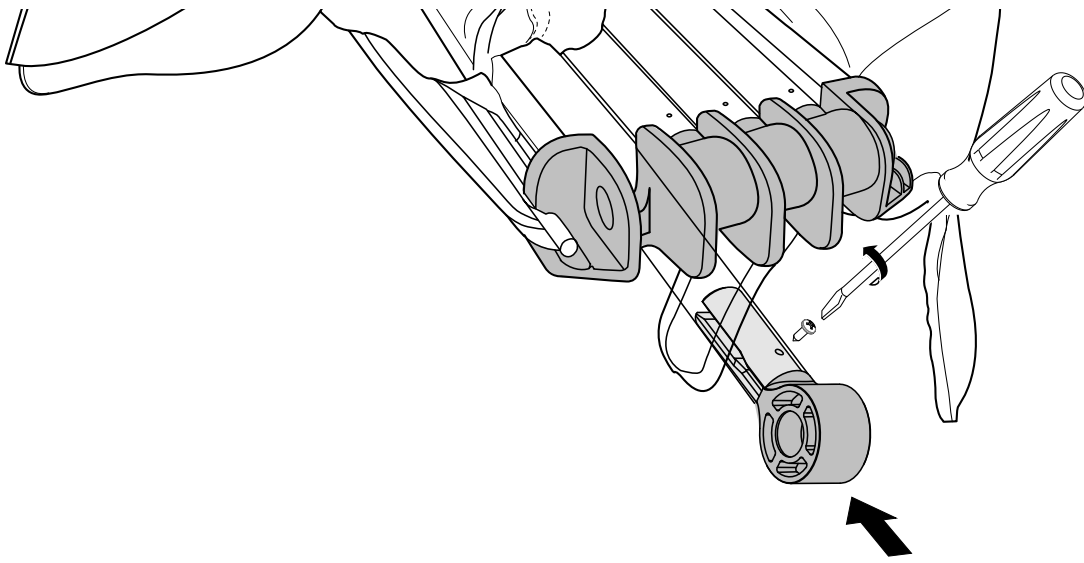

- 8** Assemble the skewer sub assembly back and tighten.

